



# RED SWASTIKA SCHOOL

## 2024 END OF YEAR EXAMINATION

### MATHEMATICS PAPER 1

Name : \_\_\_\_\_ ( )

Class : Primary 5 / \_\_\_\_\_ (Teacher: \_\_\_\_\_)

Date : 23 October 2024

### BOOKLET A

15 Questions

20 Marks

Duration of Paper 1 (Booklets A & B): 1 hour

**Note:**

1. Do not open this Booklet until you are told to do so.
2. Read carefully the instructions given at the beginning of each part of the Booklet.
3. Do not waste time. If a question is difficult for you, go on to the next one.
4. Check your answers thoroughly and make sure you attempt every question.
5. In this booklet, you should have the following:
  - (a) Page 1 to Page 5
  - (b) Questions 1 to 15
6. You are not allowed to use a calculator.



Questions 1 to 10 carry 1 mark each. Questions 11 to 15 carry 2 marks each. For each question, four options are given. One of them is the correct answer. Make your choice (1, 2, 3 or 4). Shade the correct oval (1, 2, 3 or 4) on the Optical Answer Sheet. (20 marks)

1 Which of the following is fifty-four thousand and seventy in numerals?

- (1) 5470
- (2) 54 070
- (3) 54 700
- (4) 540 070

2 What is the missing number in the box?

$$\frac{9}{12} = \frac{3}{\boxed{?}}$$

- (1) 9
- (2) 8
- (3) 6
- (4) 4

3 Arrange the following fractions from the greatest to the smallest.

$$\frac{2}{3}, \quad \frac{5}{6}, \quad \frac{7}{12}$$

- |     | <i>(greatest)</i> |                | <i>(smallest)</i> |
|-----|-------------------|----------------|-------------------|
| (1) | $\frac{5}{6}$     | $\frac{2}{3}$  | $\frac{7}{12}$    |
| (2) | $\frac{5}{6}$     | $\frac{7}{12}$ | $\frac{2}{3}$     |
| (3) | $\frac{7}{12}$    | $\frac{5}{6}$  | $\frac{2}{3}$     |
| (4) | $\frac{7}{12}$    | $\frac{2}{3}$  | $\frac{5}{6}$     |

- 4 Round 8.745 to 2 decimal places.
- (1) 8.70
  - (2) 8.74
  - (3) 8.75
  - (4) 8.80
- 5 Linda baked 200 cookies. She sold 60 of them. What percentage of the cookies Linda baked was sold?
- (1) 30%
  - (2) 40%
  - (3) 60%
  - (4) 70%
- 6 A machine takes 3 min to print 4 posters. At the same rate, how long will it take to print 24 posters?
- (1) 6 min
  - (2) 8 min
  - (3) 12 min
  - (4) 18 min
- 7 How many minutes are there in 4 hours?
- (1) 100
  - (2) 120
  - (3) 240
  - (4) 400

- 8 In the figure, AB and CD are straight lines. Which two angles are equal?

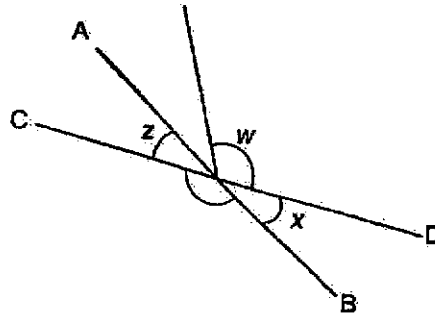

- (1)  $\angle x$  and  $\angle z$   
 (2)  $\angle y$  and  $\angle z$   
 (3)  $\angle x$  and  $\angle y$   
 (4)  $\angle w$  and  $\angle y$
- 9 The graph shows the number of handphones sold by a shop from June to September.

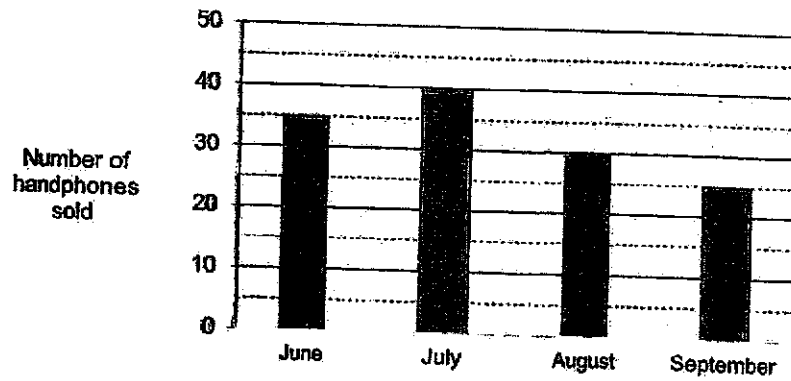

How many handphones did the shop sell in September?

- (1) 10  
 (2) 15  
 (3) 25  
 (4) 40

- 10 There are 78 canned drinks in a carton. 24 of them are mango flavoured and the rest are lychee flavoured. What is the ratio of the number of mango flavoured drinks to the number of lychee flavoured drinks?

- (1) 4 : 9  
 (2) 9 : 4  
 (3) 4 : 13  
 (4) 9 : 13

- 11 Evan was given \$4 pocket money every day from Monday to Friday. He spent \$3.20 each day from Monday to Thursday and saved the rest. He spent 30 cents more on Friday. How much did Evan save altogether?

- (1) \$3.20  
 (2) \$3.70  
 (3) \$4.00  
 (4) \$4.30

- 12 The figure below is made up of 3 identical rectangles. The breadth of the rectangle is 3 cm. The perimeter of the figure is 48 cm. What is the length of the rectangle?

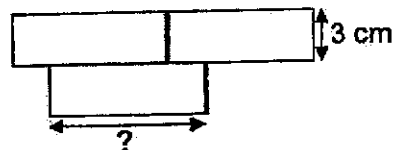

- (1) 36 cm  
 (2) 12 cm  
 (3) 9 cm  
 (4) 4 cm

- 13 A rectangular tank, 10 cm by 5 cm by 24 cm shown below is  $\frac{1}{4}$  filled with water. How much more water is needed to fill the tank to its brim?

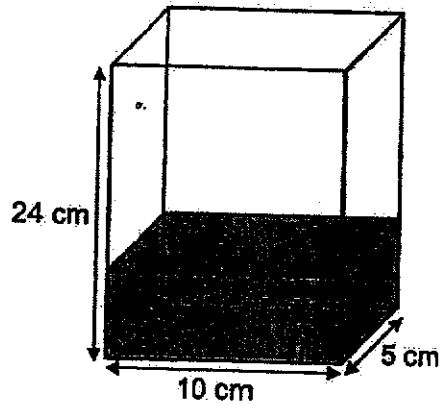

- (1)  $300 \text{ cm}^3$   
 (2)  $600 \text{ cm}^3$   
 (3)  $900 \text{ cm}^3$   
 (4)  $1200 \text{ cm}^3$
- 14 The average number of students in 3 classes is 32. Class A has 37 students while Class B has 3 more students than Class A. What is the number of students in Class C?
- (1) 19  
 (2) 24  
 (3) 27  
 (4) 96
- 15 Devi had some 10-cents, 20-cents and 50-cents coins in a box. There were twice as many 20-cent coins as 50-cent coins in the box. The number of 10-cent coins was the same as the number of 50-cent coins. The total value of all her coins was \$23. How many coins were there in the box altogether?
- (1) 23  
 (2) 46  
 (3) 69  
 (4) 92



# RED SWASTIKA SCHOOL

## 2024 END OF YEAR EXAMINATION

### MATHEMATICS PAPER 1

Name : \_\_\_\_\_ ( )

Class : Primary 5 / \_\_\_\_\_ (Teacher: \_\_\_\_\_)

Date : 23 October 2024

### BOOKLET B

15 Questions  
25 Marks

In this booklet, you should have the following:

- (a) Page 6 to Page 13  
(b) Questions 16 to 30

#### MARKS

	OBTAINED	POSSIBLE
BOOKLET A		20
BOOKLET B		25
TOTAL		45

Parent's Signature : \_\_\_\_\_





Questions 16 to 20 carry 1 mark each. Write your answers in the spaces provided. For questions which require units, give your answers in the units stated. (5 marks)

---

16 Ali listed the factors of 18 below.

1, 3, 9, 18

He missed out two factors. What are the two missing factors?

Ans: \_\_\_\_\_ and \_\_\_\_\_

---

17 What is the value of  $64 - (9 + 11) + 5 \times 2$ ?

Ans: \_\_\_\_\_

---

18 Find the value of  $7.8 + 3$

Ans: \_\_\_\_\_

---

6

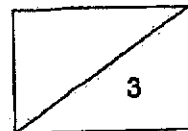

- 19 In the grid, draw a line parallel to AB and passing through C.

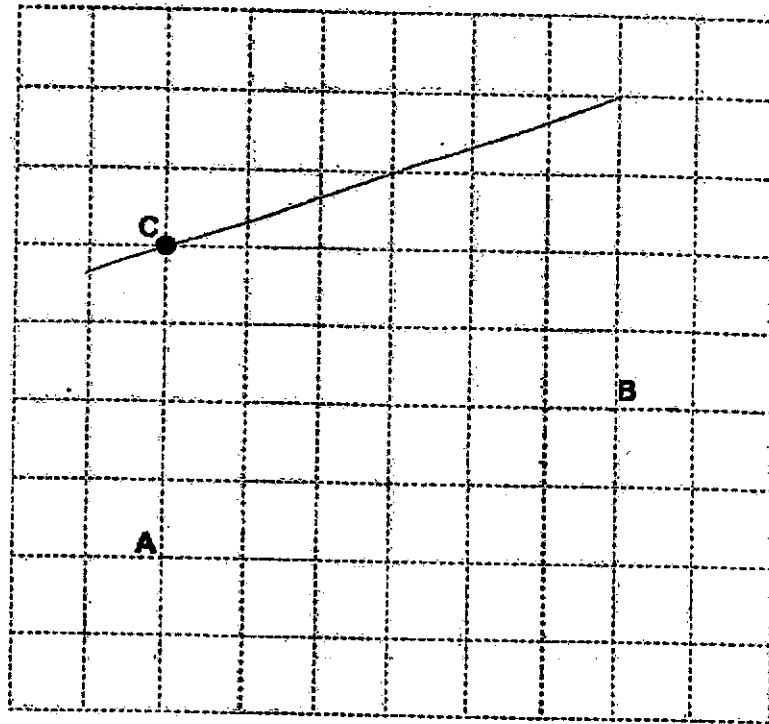

- 20 Find the value of  $\frac{4}{9} \times 5$   
Leave your answer in mixed number.

Ans: \_\_\_\_\_

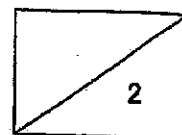

Questions 21 to 30 carry 2 marks each. Show your workings clearly in the space provided for each question and write your answers in the spaces provided. For questions which require units, give your answers in the units stated.

(20 marks)

- 21 (a) Three volumes are given below. Which is the smallest?

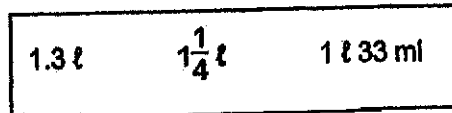

Ans: (a) \_\_\_\_\_

- (b) How much water is in the container shown?

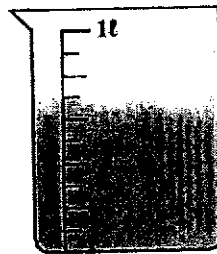

Ans: (b) \_\_\_\_\_ ml

- 22 Gabriel had 340 Pokémon cards for sale. He sold 35% of them yesterday. How many Pokémon cards did he sell yesterday?

Ans: \_\_\_\_\_

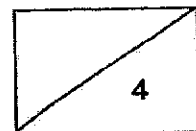

- 23 (a) Peter is standing at point A facing North. He makes a  $\frac{1}{4}$ -turn clockwise. Then he turns through an angle of  $135^\circ$  in an anti-clockwise direction. Which direction will he be facing in the end?

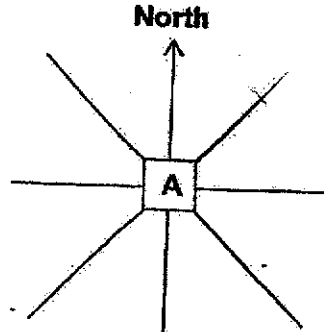

Ans: (a) \_\_\_\_\_

- (b) Complete the symmetric figure with XY as the line of symmetry.

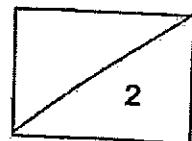
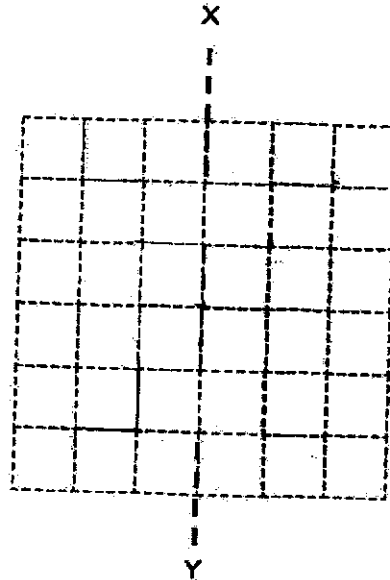

- 24 A tank was completely filled with water for a water rationing exercise at 1 p.m. The line graph shows the volume of water in the tank from 1 p.m. to 7 p.m.

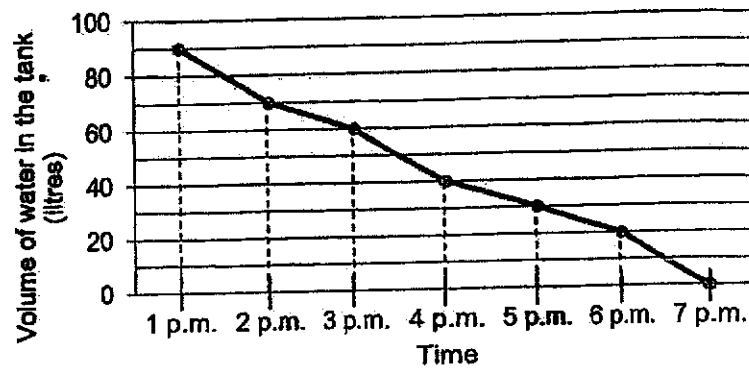

- (a) What was the capacity of the tank?

Ans: (a) \_\_\_\_\_ l

- (b) At what time was the tank  $\frac{1}{3}$  filled with water?

Ans: (b) \_\_\_\_\_ p.m.

- 25 Keming, Ray and Hassan shared a box of stickers in the ratio 5 : 9 : 3. Ray had 32 stickers more than Keming. How many stickers did the three boys have altogether?

Ans: \_\_\_\_\_

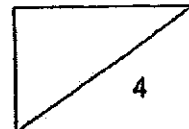

26 The solid below is made up of 11 identical cubes. The side view is as shown.

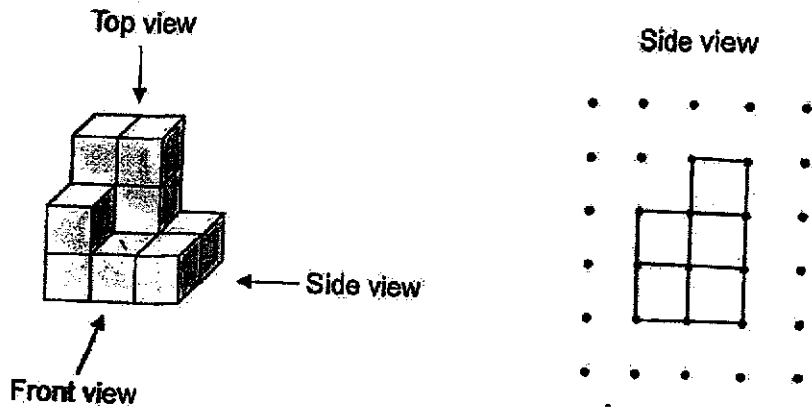

(a) Draw the front view of the solid below.

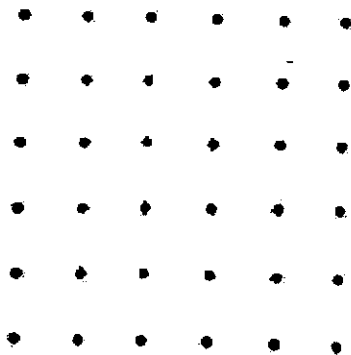

(b) Find the greatest number of unit cube(s) Gopal can add to the solid without changing the front view and side view.

Ans: (b) \_\_\_\_\_

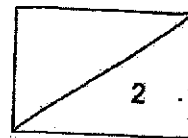

- 27 ABCD is a square of side 12 cm. It is formed from two rectangles ABGE and EGCD. F is a point on AB and G is a point on BC. Find the area of EFGH.

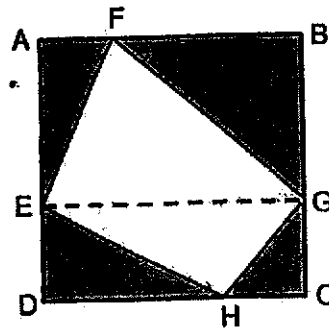

Ans: \_\_\_\_\_ cm<sup>2</sup>

- 28 The figure is made up of two identical squares overlapping each other. The overlapped part forms a shaded square with an area of 49 cm<sup>2</sup>. Find the perimeter of the figure.

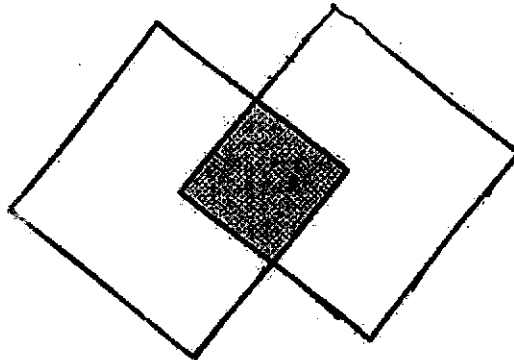

Ans: \_\_\_\_\_ cm

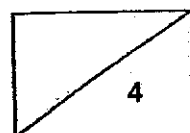



- 29 Ali used 48 tacks to pin his drawing side by side onto a board as shown.

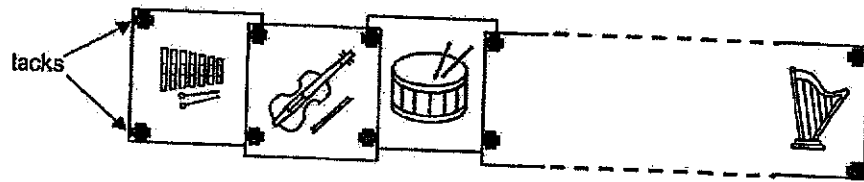

How many drawings did he pin altogether?

Ans: \_\_\_\_\_

- 30 Sam kept some red and blue pens in bags A and B. Bag A contained twice as many pens as bag B. In bag A,  $\frac{1}{5}$  of the pens were red pens and the rest were blue pens. In bag B,  $\frac{1}{3}$  of the pens were red pens and the rest were blue pens. What fraction of Sam's pens were red?

Ans: \_\_\_\_\_

END OF PAPER

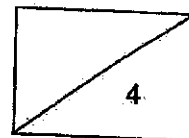



**RED SWASTIKA SCHOOL**  
**2024 END OF YEAR EXAMINATION**  
**MATHEMATICS**  
**PAPER 2**

Name : \_\_\_\_\_ ( )

Class : Primary 5 / \_\_\_\_\_ (Teacher: \_\_\_\_\_)

Date : 23 October 2024

17 Questions

55 Marks

Duration of Paper 2: 1 hour 30 minutes

**Note:**

1. Do not open this Booklet until you are told to do so.
2. Read carefully the instructions given at the beginning of each part of the Booklet.
3. Do not waste time. If a question is difficult for you, go on to the next one.
4. Check your answers thoroughly and make sure you attempt every question.
5. In this paper, you should have the following:
  - (a) Page 1 to Page 14
  - (b) Questions 1 to 17
6. You are allowed to use a calculator.

**MARKS**

	OBTAINED	POSSIBLE
PAPER 1		45
PAPER 2		55
TOTAL		100

Parent's Signature : \_\_\_\_\_



Questions 1 to 5 carry 2 marks each. Show your workings clearly in the space below each question and write your answers in the spaces provided. For questions which require units, give your answers in the units stated.

(10 marks)

1 In 38.564,

a) which digit is in the hundreds place?

Ans: (a) \_\_\_\_\_

b) what is the value of the digit 3?

Ans: (b) \_\_\_\_\_

2 a) The figure is made up of two squares. What fraction of the figure is shaded?

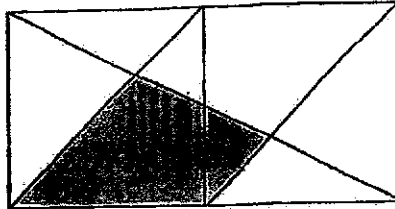

Ans: (a) \_\_\_\_\_

b) In the number line below, what is the decimal represented by A?

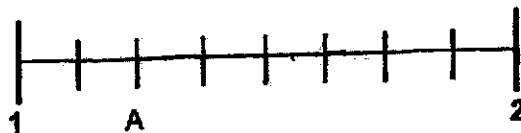

Ans: (b) \_\_\_\_\_

1

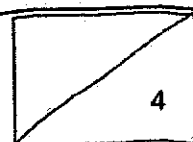

- 3 Two numbers add up to 674. Both numbers are 3-digit numbers. What is the greatest possible difference between the two numbers?

Ans: \_\_\_\_\_

- 4 The rate to send letters to a country is shown in the table below.

Letters	First 20 g	\$0.85
	Every additional 10 g or part thereof	\$0.25

Ben sent a letter that weighed 43 g. How much did Ben pay for sending the letter?

Ans: \$ \_\_\_\_\_

2

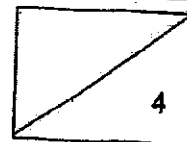

- 5 The figure shows a square,  $WXYZ$ .  $\angle UYX$  is  $21^\circ$  and  $\angle WZU$  is  $48^\circ$ .

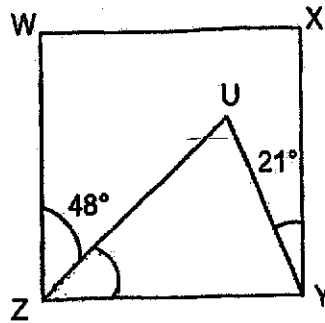

- a) Find  $\angle UZY$ .

Ans: (a) \_\_\_\_\_ $^\circ$

- b) Circle the words that describe triangle  $ZUY$  in the statement.

ZUY (is / is not) an isosceles triangle because  $\angle YUZ$   
(is / is not) equal to  $\angle ZYU$ .

2

For Questions 6 to 17, show your workings clearly in the space below each question and write your answers in the spaces provided. The number of marks available is shown in brackets [ ] at the end of each question or part-question. (45 marks)

- 6 In a library, books were placed on 40 shelves with equal number of books on each shelf. 6 shelves were removed and the books on these shelves were placed on the remaining 34 shelves. Because of this, the number of books on each shelf increased by 9. What was the number of books on each shelf at first?

Ans: \_\_\_\_\_ [3]

- 7 Miss Tan decorated a frame, 28 cm long by 16 cm wide, with identical rectangular tiles using the tiling pattern shown below.

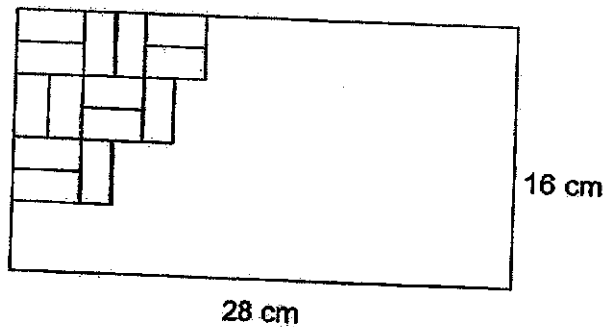
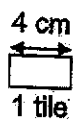

How many tiles did Miss Tan use altogether?

Ans: \_\_\_\_\_ [3]

4

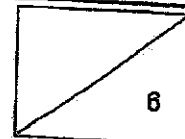

- 8 The mass of a box with 50 identical beads weighs 0.9 kg. When 30 beads are removed, the mass of the box with the remaining beads is 0.54 kg. What is the mass of each bead in kilogram?

Ans: \_\_\_\_\_ [3]

- 9 A shop sells dresses in four different sizes. The table below shows the number of dresses sold last Saturday for size S, M and XL but not L.

Size of dress	Number of dresses sold
S	16
M	49
L	
XL	47

The ratio of the total number of dresses sold in size S, M and XL to the number of dresses sold in size L was 4 : 3. Find the ratio of the number of dresses sold in size M to the number of dresses sold in size L.  
(Give your answer in the simplest form.)

Ans: \_\_\_\_\_ [3]

5

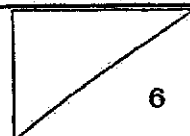



- 10 A baker baked some cupcakes for sale on Saturday morning. He sold 65% of the cupcakes on Saturday and found that he had 203 cupcakes left.

a) How many cupcakes did the baker bake on Saturday morning?

Ans: (a) \_\_\_\_\_ [1]

- b) He sold the remaining cupcakes on Sunday at a discount of 20%. How much were all the cupcakes sold for on Sunday?



**1 for \$3.50**

Ans: (b) \_\_\_\_\_ [2]

6

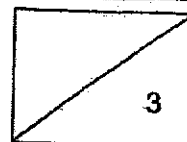

- 11 The graph shows the cost of food delivery a company charges for delivering meals for the first 10 kilometres.

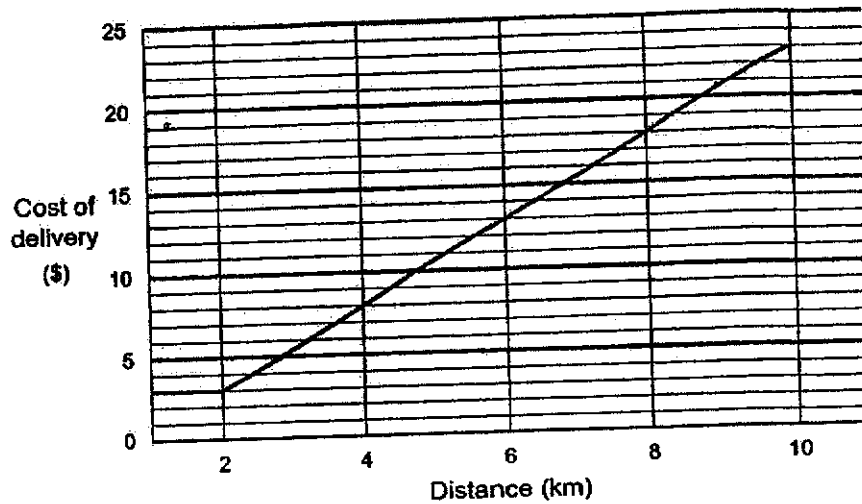

- a) How much would it cost to deliver a meal that is within 2 km?

Ans: (a) \_\_\_\_\_ [1]

- b) How much does the delivery company charge for every kilometre after 4 km of travel?

Ans: (b) \_\_\_\_\_ [2]

- c) The delivery man has to drive 9 km to Peggy's house. How much is her delivery charge?

Ans: (c) \_\_\_\_\_ [1]

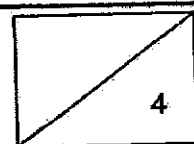

- 12 In the figure, ACG is a triangle and ABEG is a trapezium. BDE is an isosceles triangle and BH is parallel to CG. D and F are points on the straight line CG.  $\angle ABH = 41^\circ$  and  $\angle DBC = 31^\circ$ .

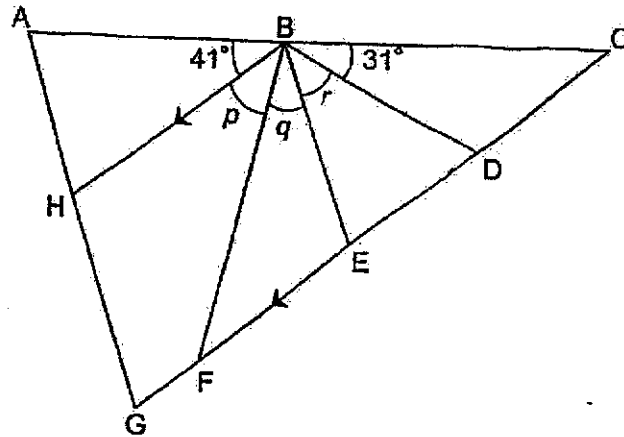

- a) Find  $\angle r$ .

Ans: (a) \_\_\_\_\_ [2]

- b) Each of the statements below is either true, false or not possible to tell from the information given. For each statement, put a tick ( $\checkmark$ ) to indicate your answer.

Statement	True	False	Not possible to tell
$\angle p = \angle q$			
HBEG is a parallelogram.			
$\angle p + \angle q$ is twice of $\angle r$ .			

[2]

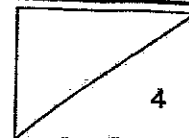

- 13 Mrs Chan bought an equal number of pots and pans. The ratio of the cost of a pot to the cost of a pan was 3 : 2. The average price of a pot and a pan was \$11.25. Mrs Chan paid \$45 less for the pans than the pots.

(a) How many pans did Mrs Chan buy?

5 x 3

Ans: (a) \_\_\_\_\_ [3]

(b) Mrs Chan bought two more pans.

Circle the words that describe the new average price in the statement.

[1]

The new average price of the items she bought is (more than / less than / the same as) \$11.25.

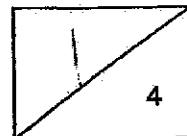

- 14 The bar graph shows the number of books sold in a book store from September to November. The number of books sold is not given in the scale. The number of books left unsold at the end of each month is represented in the line graph. The number of books left unsold is also not given in the scale.

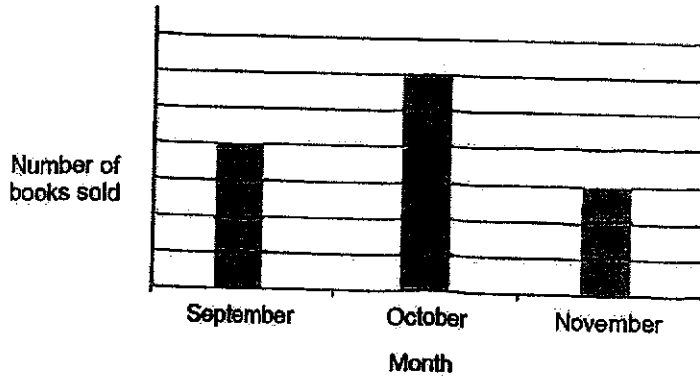

Figure 1

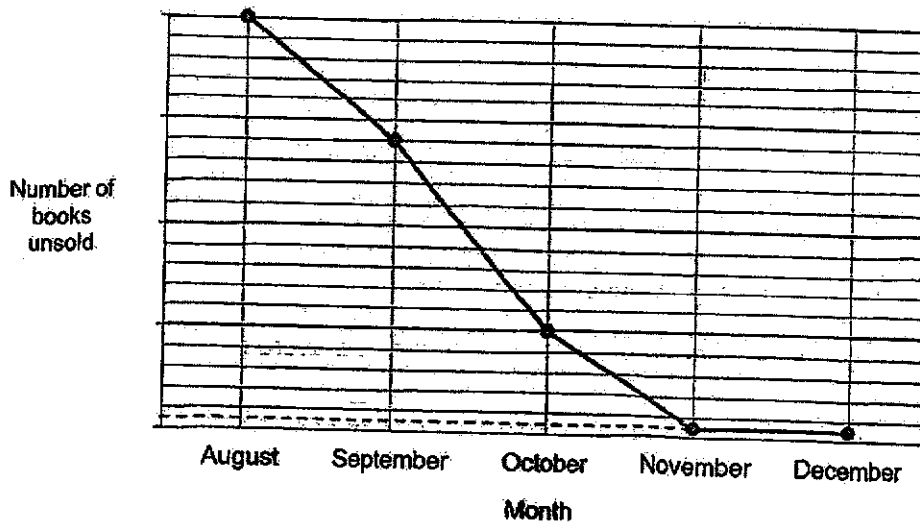
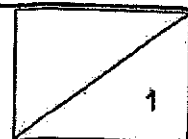

Figure 2

- (a) Based on the information in Figure 1, what fraction of the books sold in the three months were sold in October?

Ans: (a) \_\_\_\_\_ [1]



- (bi) Given that 18 books were sold in the month of November, how many books were sold from September to November?

Ans: (bi) \_\_\_\_\_ [1]

- (bil) What was the number of books left unsold in the book store in December?

Ans: (bil) \_\_\_\_\_ [2]

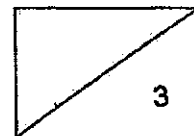

- 15 A total of 81 students were assigned to welcome guests during a school event. They were to line up in a row along the corridor. There were at least 3 girls between any 2 boys.

(a) What was the greatest possible number of boys in the row along the corridor?

Ans: (a) \_\_\_\_\_ [2]

(b) What was the ratio of the number of girls to the number of boys at the school event? (Express your answer in its simplest form.)

Ans: (b) \_\_\_\_\_ [2]

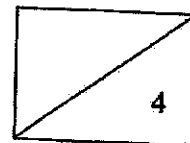

- 16 Two children used the same number of ice cream sticks to make toy houses. Don used  $\frac{6}{7}$  of his ice cream sticks while Lea used  $\frac{3}{4}$  of her ice cream sticks. They had a total of 4350 ice cream sticks at first.

(a) How many ice cream sticks did each of them use?

Ans: (a) \_\_\_\_\_ [3]

(b) Lea wanted to give Don some of her remaining ice cream sticks. How many ice cream sticks must Lea give Don such that they will have an equal number of ice cream sticks left?

Ans: (b) \_\_\_\_\_ [2]

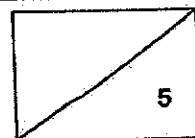



- 17 The figure is made up of two identical right-angled triangles that overlap with each other and  $PQ = 10$  cm.

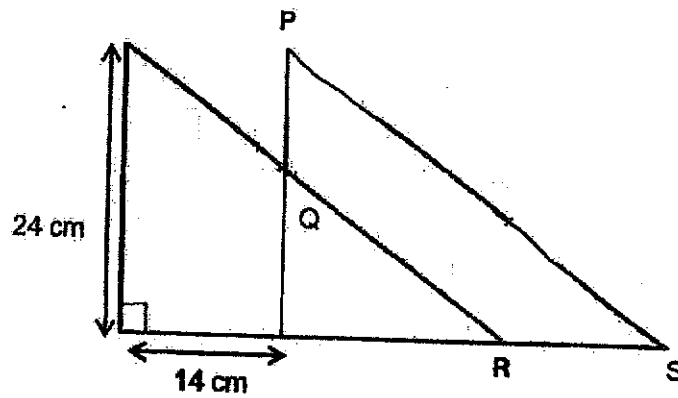

- (a) Find the length of RS.

Ans: (a) \_\_\_\_\_ [1]

- (b) Find the area of the shaded part

Ans: (b) \_\_\_\_\_ [4]

END OF PAPER

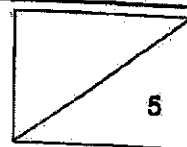



SCHOOL : RED SWASTIKA SCHOOL  
 LEVEL : PRIMARY 5  
 SUBJECT : MATHEMATICS  
 TERM : SA2

## PAPER 1

## BOOKLET A

Q1	Q2	Q3	Q4	Q5	Q6	Q7	Q8
2	4	1	3	1	4	3	1
Q9	Q10	Q11	Q12	Q13	Q14	Q15	
3	1	2	3	3	1	4	

## BOOKLET B

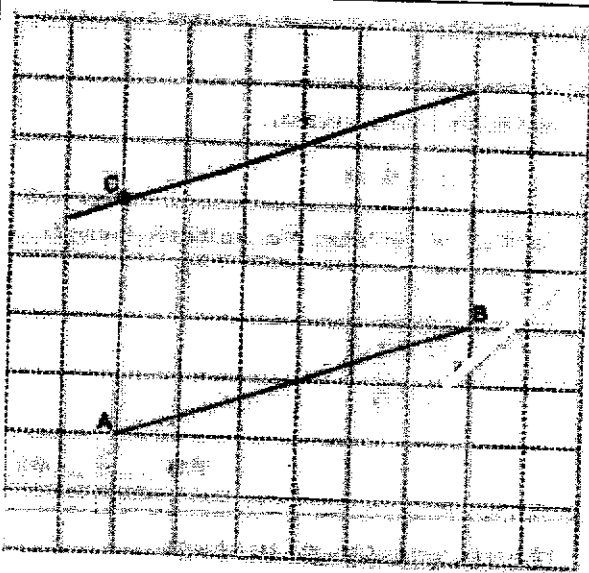
Q16	2 and 6
Q17	56
Q18	2.6
Q19	
Q20	$2\frac{2}{9}$

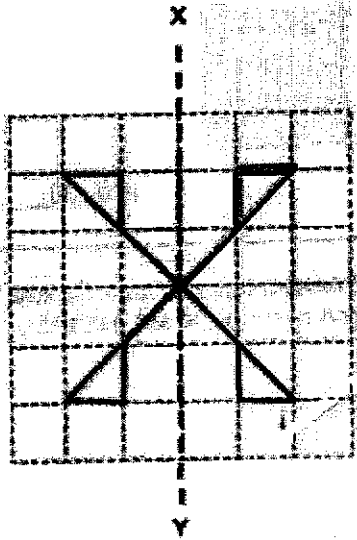
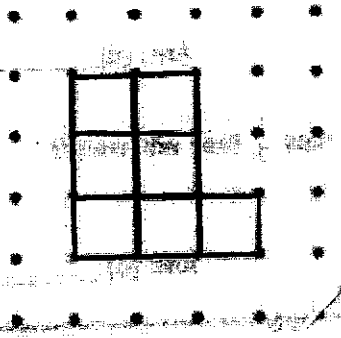
Q21 (a)	1L 33ml
Q21 (b)	700
Q22	$340 \times 35\% = 119$
Q23 (a)	North-west
Q23 (b)	
Q24 (a)	90
Q24 (b)	5
Q25	$4u = 32$ $17u = 136$
Q26 (a)	
Q26 (b)	1
Q27	$\frac{1}{2} \times 12 \times 12 = 72$

Q28	$\sqrt{49} = 7$ $7 \times 12 = 84$
Q29	No. of drawings = $\frac{48 - 2}{2} = 23$
Q30	$\frac{11}{45}$

## PAPER 2

Q1 (a)	5
Q1 (b)	30000
Q2 (a)	$\frac{1}{4}$
Q2 (b)	1.25
Q3	1st number = 100 2nd number = $674 - 100 = 574$ $574 - 100 = 474$
Q4	$\$0.85 + \$0.25 + \$0.25 + \$0.25 = \$1.60$
Q5 (a)	$90 - 48 = 42$
Q5 (b)	Is, is
Q6	6 shelves = $34 \times 9 = 306$ 1 shelf = 51
Q7	4 squares = 16cm 7 squares = 28cm Total squares = $4 \times 7 = 28$ Total tiles = $28 \times 2 = 56$
Q8	30 beads = $0.9 - 0.54 = 0.36$ 1 bead = $0.36 \div 30 = 0.012\text{kg}$
Q9	$4u = 112$ $3u = (112 \div 4) \times 3 = 84$ M : L 49 : 84

	7 : 12												
Q10 (a)	$35\% = 203$ $100\% = \frac{203}{35} \times 100 = 580$												
Q10 (b)	$20\% = \$3.50 \times 80\% = \$2.80$ $\$2.80 \times 203 = \$568.40$												
Q11 (a)	\$3												
Q11 (b)	$\$5 \div 2 = \$2.50$												
Q11 (c)	\$20.50												
Q12 (a)	$\angle p + \angle q + \angle r = 180^\circ - 41^\circ - 31^\circ = 108^\circ$ $\angle a = 180^\circ - 108^\circ = 72^\circ$ $\angle r = 180^\circ - 72^\circ - 72^\circ = 36^\circ$												
Q12 (b)	<table border="1" style="border-collapse: collapse; text-align: center;"> <thead> <tr> <th style="width: 33%;"></th> <th style="width: 33%;"></th> <th style="width: 33%;">Not possible (Q26)</th> </tr> </thead> <tbody> <tr> <td></td> <td></td> <td>✓</td> </tr> <tr> <td>✓</td> <td></td> <td></td> </tr> <tr> <td>✓</td> <td></td> <td></td> </tr> </tbody> </table>			Not possible (Q26)			✓	✓			✓		
		Not possible (Q26)											
		✓											
✓													
✓													
Q13 (a)	1 pot = $(11.25 \times 2) \div (5 \times 3) = 13.50$ 1 pan = $(11.25 \times 2) \div (5 \times 2) = 9$ Difference = $13.50 - 9 = 4.50$ Pans bought = $45 \div 4.5 = 10$												
Q13 (b)	Less than												
Q14 (a)	$\frac{6}{13}$												
Q14 (b)	(i) $3u = 18$ $13u = 78$  (ii) $(24 \div 6) \times \frac{1}{2} = 2$												
Q15 (a)	Sets of 4 = $(81 - 1) \div 4 = 20$ Boys = $20 + 1 = 21$												

Q15 (b)	60 : 21 20 : 7
Q16 (a)	$15u = 4350$ $6u = (4350 \div 15) \times 16 = 1740$
Q16 (b)	Lea = $(1740 \div 6) \times 8 = 2320$ Lea left = $2320 - 1740 = 580$ Don left = $1740 \div 6 = 290$ Difference = $580 - 290 = 290$ Lea must give Don = $290 \div 2 = 145$
Q17 (a)	14cm
Q17 (b)	$A = 14 \times 14 = 196$ $B = \frac{1}{2} \times 10 \times 7 = 70$ Shaded = $196 + 70 = 266$

